

# A Survey of QoS Multicast Protocols for MANETs

Ajita Sethi

B.Tech Student Department of CSE ITM GIDA, Gorakhpur

Sangeeta Suthar

B.Tech Student Department of CSE ITM GIDA, Gorakhpur

Vibhawari Yadav

B.Tech Student Department of CSE ITM GIDA, Gorakhpur

Ajay Kumar

Assistant Professor Department of CSE ITM GIDA, Gorakhpur

**Abstract** – Since we are using mobile Ad hoc networks extensively, a number of issues have been arrived for multicasting communication in MANETs. The major issue is providing quality of service that needs attention. There are many protocols evolved to overcome this issue, so that QoS can be improved. The objective of this paper is to study a few multicasting routing protocols for MANET and to grade them on the basis of their performance in a constant simulation scenario. In this paper we study Source-Based Multicast Routing Protocol like Multicast Routing Protocol (DVMRP), Multicast Extension To Open Shortest Path First Protocol (MOSPF), Protocol Independent Multicast- Dense Mode (PIM-DM) and Core-Based Multicast Routing Protocol like The Core-Based Tree (CBT) Protocol, PIM-Sparse Mode (PIM-SM) and very recently Simple Multicast (SM).

**Index Terms** – Multicasting, CBT, PIM-DM, PIM-SM, QoS.

## 1. INTRODUCTION

Routing is key important operation for successful data transmission in packet switching networks. Multicast routing transmits packets from one or multiple sources to multiple receivers. IP network provide best effort service that is subject to unpredictable delay and potential data loss.

There has been phenomenal growth of group communication and QoS [1] aware application over internet that calls needs for scalable and efficient network support. Applications like DIS (Distributed Interactive Simulations), Resource locations, shared workspace, video conferencing and software upgrading etc. cannot operate with the best effort service provided by current IP network.

The vulnerabilities that a MANET can be subjected to are as follows:

1. Cooperativeness
2. Scalability
3. Dynamically changing topology
4. Lack of centralized management
5. No fixed boundaries

## 6. Battery supplied mobile devices

These vulnerabilities have led to some issues. The movement and mobility of senders and receivers creates considerations that affect the network performance, the following are the considerations

- Deployment consideration:
  - Scalability
  - Interoperability
  - Packet delivery rate
  - QoS
  - Service pricing
  - Security
- Routing mechanism
  - Core placement
  - Tunneling
  - Routing state maintenance
  - Network inactivity
  - Tree construction
- Receiver behavior
  - Leave latency
  - Packet duplication
  - Join latency
  - Packet out of order

## 2. TAXONOMY OF MULTICAST ROUTING PROTOCOLS

The concept of multicasting was launched by Steve Deering in 1980's, early efforts in the 1980's to define a multicast capable Internet resulted in a RFC 966, "Host Groups: A Multicast Extension to the Internet Protocol" (1985). IP multicast concepts evolved through additional RFCs (988 and 1054), resulting in the multicast standard, in RFC 1112, "Host Extension for IP Multicasting" (1989). Additional work in the early 90s led to the creation of Virtual Internet Backbone for Multicast IP or Mbone, which was an experimental test bed system for multicast application and protocol development.

Mbone was first deployed in 1992 as a virtual network, with application-layer packet replication: one packet in, one or more packets out. From Mbone's flat, virtual set of networks in 1992, all under the same Autonomous System (AS) [2] or domain, multicast routing has evolved from an intra-domain routing emphasis to a broader scope of inter-domain routing in the late 1990's, supporting a hierarchical set of domains.

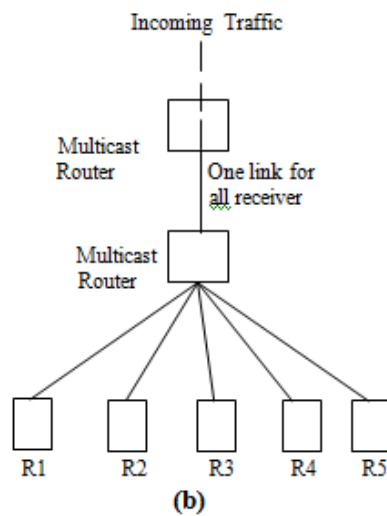
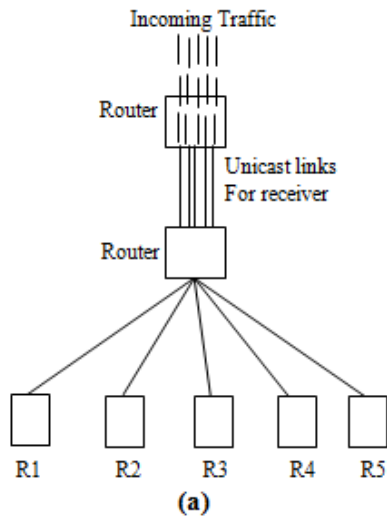

Figure 1 (a) Delivery of information using multiple unicasting and (b) multicasting.

There are many different types of issues in which the multicast routing protocols are classified into different categories. They can be classified on the basis of how multicast connectivity is established and maintained, who's named is, source-imitated and receiver imitated. In source-imitated approach, the formation of the multicast group is initiated by the source and a tree or mesh is constructed per sender. The source polls the network periodically with join-

request packets, the receivers willing to join the multicast group respond with reply packets after receiving the requests. In a receiver imitated approach, a receiver floods a join request packet to search for a path to a multicast group. One important technique used in this approach is to assign a node, known as the Rendezvous Point (RP) [2] or the core, to accept join requests from members. Finally, multicast routing protocols are classified into tree-based and mesh based protocols based on the topology [5] in tree-based protocols, there exists only one possible path between a source-destination pair, whereas in mesh-based protocols, there may exist more than one path [6].

The classification of existing multicast routing protocols both in wired and wireless networks have been classified based on the topology into source-based tree, shared-based tree and mesh-based protocols. The source-based trees uses the shortest path for minimum delay, these structures is appropriate for regions where group members are densely distributed. On the other hand, shared-based trees have better resource utilization than source-based trees, where increases the traffic concentration. The tree based protocols are more efficient in terms of resource usage and mesh-based protocols are more robust to the changes in the network.

The classifications of multicasting routing protocols [3] are described in figure 2.

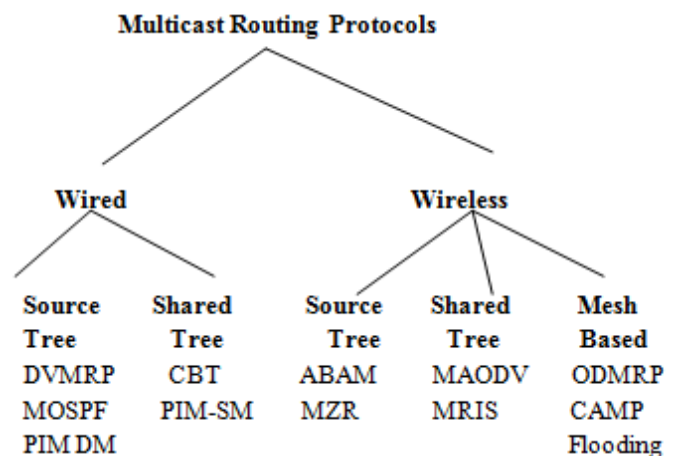

Figure 2 Classification of Multicast Routing Protocols

### 3. MULTICASTING IN WIRED NETWORK

The wired multicast routing protocols are defined in two categories: Source-based and Core-based.

#### 3.1 Source-Based Multicast Routing Protocol

A rooted tree is constructing in which root working as a source node and connected to every member in the multicast group. In this protocol data packets are originating from source node and send to all destination nodes through communication link of a multicast tree. The Distance Vector

Multicast Routing Protocol (DVMRP)[7], Multicast Extension To Open Shortest Path First Protocol (MOSPF)[8], Protocol Independent Multicast- Dense Mode (PIM-DM)[9], and very recently Explicitly Requested Single-Source Multicast (EXPRESS)[10] comes in the category of source-based trees.

### 3.1.1 Distance Vector Multicast Routing Protocol (DVMRP)

DVMRP is a source-based multicast routing protocol which uses the Reverse-Path Multicast (RPM) algorithm. DVMRP was first defined in RFC-1075. The original specification was derived from the Routing Information Protocol (RIP) and employed the Truncated Reverse Path Broadcasting (TRPB) algorithm. The major difference between RIP and DVMRP is that RIP is concerned with calculating the next hop to a destination, while DVMRP is concerned with computing the previous hop back to source.

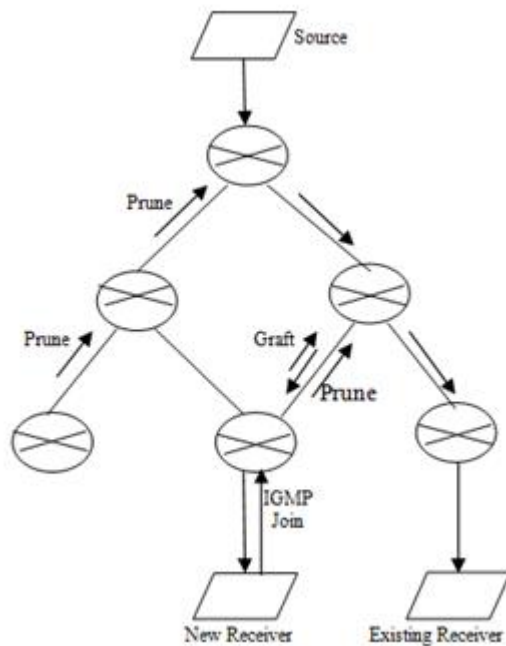

Figure 3 Message flowing in DVMRP

As illustrated in figure: 3, the first packet of multicast message send from a source to a particular multicast group is flooded leaf to the source over the network. Then, prune message send by router are used to truncate the branches which do not lead to a group member. Furthermore, a new type of message is quickly used called “graft”. The “graft” message send by the new receiver to the source, which is currently joins that multicast group. Similar to prune message which are forwarded hop by hop, graft message are send back on hop at a time until they reach a node which is on the multicast delivery tree.

### 3.1.2 Multicast Open Shortest Path First Protocol (MOSPF)

The Multicast extension to OSPF (MOSPF) defined in RFC 1584 are built on the top of Open Shortest Path First (OSPF) Version 2 (RFC 1583). MOSPF uses the group membership information obtained through IGMP [11] and with the help of OSPF database builds multicast delivery trees. These trees are Shortest-Path Trees constructed (on demand) for each (source, group) pair. MOSPF supports hierarchical routing. All hosts in the Internet are partitioned in to some “Autonomous System” (AS). Each AS is further divided in to subgroups called “areas”.

In OSPF, each router with in a routing domain keeps state and topological information of this domain; this is achieved by link-state advertisement (LSA) flooding.

A shortest path tree rooted at the source using Dijkstra’s algorithm has builded by MOSPF router. After the building of tree, group membership information is used for pruning for those branches that do not lead to sub networks with group members resulting, a pruned Shortest-path tree in which source as a route. The MOSPF router creates a forwarding table and then determines its position in the shortest-path tree. The forwarding table is not changing after a fixed interval but when the network topology or group membership have changed the forwarding table has also changed.

### 3.1.3 Protocol Independent Multicasting-Dense Mode (PIM-DM)

PIM contains two protocols: PIM-Dense Mode (PIM-DM) which performs better in cases where the group members are densely distributed and PIM-Sparse Mode (PIM-SM) which is more efficient when the group members are distributed over many regions of the network. PIM-DM is very similar to the DVMRP in that it requires the presence of unicast routing protocol for finding routes back to the source node. The other difference between PIM-DM and DVMRP is that PIM-DM forwards multicast message to all downstream hosts until it received a prune message, while DVMRP forwards multicast traffic to child nodes in the delivery tree. PIM-DM Different from DVMRP and MOSPF Protocols; DVMRP uses RIP like exchange message to build its unicast routing table, and MOSPF relies on OSPF link state database.

### 3.2 Core-Based Multicast Routing Protocol

One node is selected for each group called core or rendezvous point (RP) [13, 14]. A root of the tree defined as a core is then constructed to span all the group members. The Core-Based Tree (CBT) Protocol [15], PIM-Sparse Mode (PIM-SM) [16] and very recently Simple Multicast (SM) [17] are comes in the core-based multicasting routing protocols.

### 3.2.1 Protocol Independent Multicasting-Sparse Mode (PIM-SM)

PIM-SM which is defined in RFC 2117 has two major differences with dense mode protocols (DVMRP, MOSPF and PIM-DM). In PIM-SM protocol the routers need to explicitly announce their will for receiving multicast message of multicast group [18], while in dense mode protocols suppose that, all routers have needed to receive multicast message unless explicitly prune message has send. The other difference is the concept of “Rendezvous Point” (RP) or “Core” which has been used in PIM-SM protocol [12].

In PIM-SM assigning a set of RPs for each group, where one RP is working as a Primary RP and it is responsible for forwarding all the packets. If any routers want to receive multicast message from another group then it needs to send a join message to RP of that group. Each of the multicast host has a designated router (DR), which manages the multicast group membership messages in its group. If any host in its group wants to join another group it sends a join message to the DR, when DR receives an IGMP messages, which indicates the membership of a host to a certain group then DR finds the RP of that group with the help of performing a deterministic hash function on the sparse-mode region's RP-sets and unicast-PIM join message forwarding to the RP. The entry is created in the multicast forwarding table of the DR and intermediate routes for the (source, group) pair, such that they can know how to forward multicast message coming from RP of that multicast group to the DR and group members [16]. If the source node wants to send a message to a certain group, then it has to first register itself with the RP sending through a PIM-SM-Register message. The DR of that source encapsulates this message and sends it towards the RP of that group as a unicast message. After that the RP sending backs a PIM-Join message to the DR of the source.

Although, PIM-SM is based on the shared tree, it provides a method for shortest-path trees on the behalf of receivers. After joining a shared tree, if a receiver finds another optimal route to the source, it sends a join message towards the active source [4]. After constructing the source-based shortest path tree, the router can send a prune message to the RP and hence disassociates itself from the shared tree.

### 3.2.2 Core-Based Tree (CBT) Mode

The latest algorithm developed for constructing multicast deliver tree called core-based tree (CBT) algorithm. A single delivery tree is created by multicast CBT for each group. The “Core” router for a delivery tree is chosen by single or a set of routers. All messages are forwarded as unicast messages towards the core router until they reached a router which belongs to the corresponding delivery tree. After that the message is forwarded to all ongoing interfaces except the incoming interfaces. This has been described in fig: 3.

The multicast routers have required keeping less information as compared to the requirement of other routing algorithms. CBT preserves more network bandwidth because it has not required flooding for any multicast packet. Although, using a single tree for each group may lead to traffic concentration around the core routers.

### 3.2.3 Simple Multicast (SM)

Perlman et al [17] proposed a multicast routing protocol called Simple Multicast, which extends CBT and works both within and between domains. SM [15] appears CBT in terms of member join/leave, tree maintenance and data transfer. The main difference between CBT and SM is that how they resolve the multicast address allocation problems. SM identifies a group by the 8-byte combination of a core node and the multicast addresses [18].

## 4. SUMMARY

In this paper we study Source-Based Multicast Routing Protocol like Multicast Routing Protocol (DVMRP), Multicast Extension to Open Shortest Path First Protocol (MOSPF), Protocol Independent Multicast- Dense Mode (PIM-DM) and Core-Based Multicast Routing Protocol like The Core-Based Tree (CBT) Protocol, PIM-Sparse Mode (PIM-SM) and very recently Simple Multicast (SM).

## REFERENCES

- [1] K.Shankar and S. Audithan, “Analysis of QoS Multicast Protocols for MANETs” in 2nd International Conference on Current Trends in Engineering and Technology, ICCTET'14 IEEE 2014 IEEE Conference Number – 33344 July 8, 2014, Coimbatore, India pp 472-474.
- [2] Abhinandan Tripathi, A.K. Gupta and Dr. Deepak Arora, “Comparative Analysis of Quality of Service of Dense and CBT Mode of Multicast Routing Strategies” in International Journal of Scientific and Research Publications, Volume 3, Issue 2, February 2013 ISSN 2250-3153.
- [3] Hrishikesh Gossain., “Multicast: Wired to Wireless”, IEEE Communication magazine, June 2002.
- [4] S.Deering., “Multicast Routing in a Datagram Network”, Ph.D. dissertation, Stanford university, 1991.\
- [5] I.F. Akyildiz, W. Yen, and B. Yener, “A New Hierarchical Routing Protocols for Dynamic Multihop Wireless Networks,” Proceeding of the IEEE Conference on Computer Communications (INFOCOM), Kobe, Japan April 1997, pp. 1422-1429.
- [6] Ajay Kumar and S.P.Singh, “Performance Analysis Of Routing Protocols based on Centre and Dense Mode Routing Strategies”,IJTS,ISSN 2277-1905, Feb 2011.
- [7] Pusateri, T.,”Distance Vector Multicast Routing Protocol. IETF Internet draft (draft-ietf-idmr-dvmrp-v3-10), 2000.
- [8] Moy, J., “Multicast Routing Extensions for OSPF”, Communications of the ACM, vol. 37, no. 8, 1994, pp. 61-66.
- [9] Adams, A., Nicholas, J., and Siadak, W., “Protocol Independent Multicast - Dense Mode (PIM-DM): Protocol Specification (Revised)”, RFC 3973, NextHop Technologies, January, 2005.
- [10] H.W. Holbrook and D.R. Cheriton., “IP Multicast Channels: EXPRESS support for large- scale Single Source Applications”, ACM SIG COMM'99,1999.
- [11] W.Fenner., “Internet Group Management Protocol, version2 {IGMPv2}”, internet draft 1996.
- [12] Bin Wang., “Multicast Routing and its QoS Extension:Problem Algorithm, and Protocols”, IEEE, Jan/Feb 2000.

- [13] Estrin, D., Farinacci, D., Helmy, A., Thaler, D., Deering, S., Handley, M., Jacobson, V., Liu, C., Sharma, P., and Wei, L., "Protocol Independent Multicast-Sparse Mode (PIM-SM): Protocol Specification", RFC 2362, June, 1998.
- [14] Lin, J., "A Comparison of the Internet multicast routing protocol", computer communication, vol.22, pp.144-155, 1999.
- [15] Ballardie, T., Francis, P., and Crowcroft, J., "Core Based Trees (CBT) – An Architecture for Scalable Inter-Domain Multicast Routing", In Proceedings of ACM SIGCOMM'93, San Francisco, CA, 1993, pp. 85-95.
- [16] Fenner, B., Handley, M., Holbrook, H., and Kouvelas, I., "Protocol Independent Multicast—Sparse Mode (PIM-SM): Protocol Specification (revised)", IETF Internet draft, draft-ietf-pim-sm-v2-new-05.txt, March, 2006.
- [17] R.Perlman., et al., "Simple Multicast: A Design For Simple, Low Overhead Multicast", draft-perlman-Simple-Multicast-01, October 1998.
- [18] Chuck. Semeria., "Introduction to IP Multicasting Routing", Internet draft.